

# / TAPER BUSHES

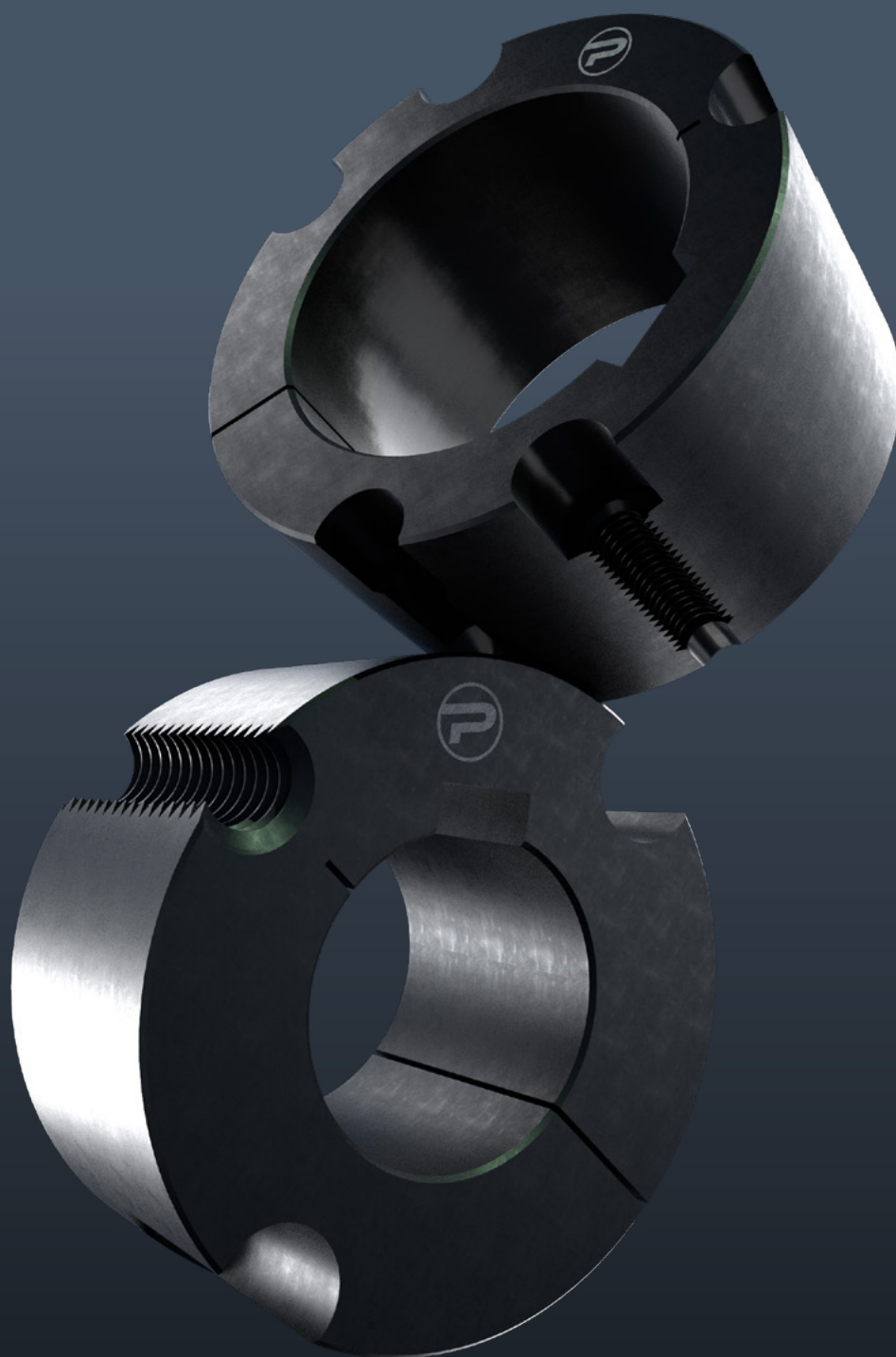

**PROTORQUE®**

# / Taper Bushes

Protorque taper bush is a reliable and time saving solution for easy installation and dismantling from shafts with key.

Conical bushes in cast iron (GG25) with phosphated surface treatment, finished bore and keyway. Bushes available from size 1008 to 5050.

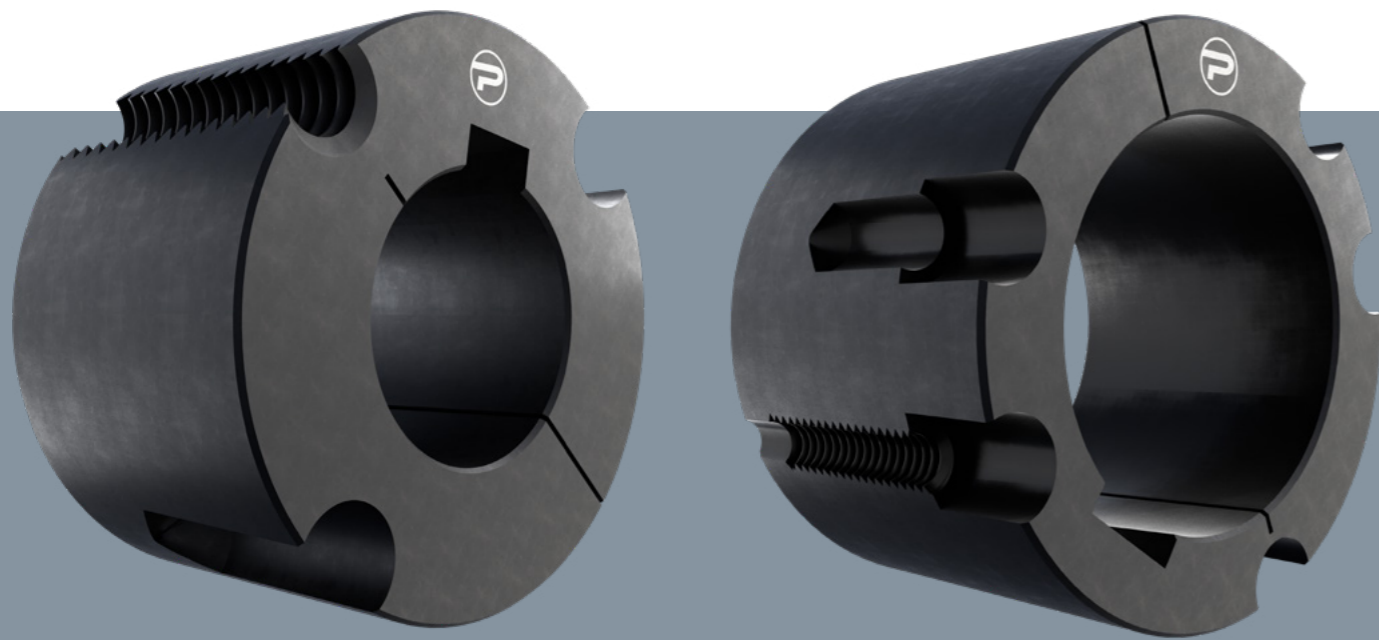

# / Dimension of Taper Bush

## 1008 - 3030

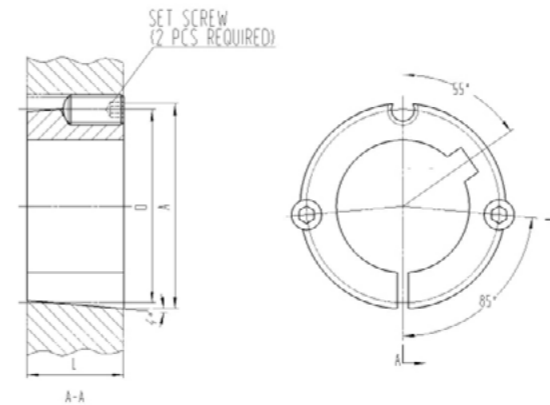

Bush No.	L [mm]	A [mm]	D [mm]	Screw dia x length, BSW, inch	Hex key dim.	Tightening torque [Nm]
1008	22,3	35,1	33,7	1/4 x 1/2	3	5,6
1108	22,3	38,2	36,9	1/4 x 1/2	3	5,6
1210	25,4	47,5	44,5	3/8 x 5/8	5	20
1215	38,1	47,5	44,5	3/8 x 5/8	5	20
1310	25,4	50,7	47,6	3/8 x 5/8	5	20
1610	25,4	57,1	53,9	3/8 x 5/8	5	20
1615	38,1	57,1	53,9	3/8 x 5/8	5	20
2012	31,8	69,8	66,7	7/16 x 7/8	6	31
2517	44,5	85,7	82,6	1/2 x 1	6	48
3020	50,8	107,9	101,6	5/8 x 1 1/4	8	90
3030	76,2	107,9	101,6	5/8 x 1 1/4	8	90

## 3525 - 5050

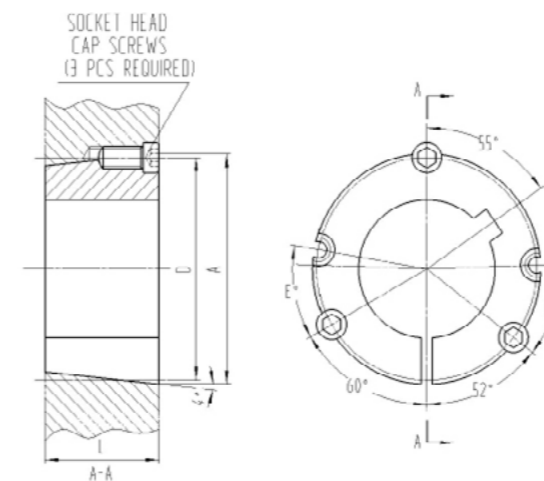

Bush No.	L [mm]	A [mm]	D [mm]	Screw dia x length BSW, inch	Hex key dim.	Tightening torque [Nm]
3525	63,5	126,8	122,6	1/2 x 1 1/2	10	112
3535	88,9	126,8	122,6	1/2 x 1 1/2	10	112
4030	76,2	145,8	140,7	5/8 x 1 3/4	12	170
4040	101,6	145,8	140,7	5/8 x 1 3/4	12	170
4535	88,9	161,7	155,7	3/4 x 2	14	192
4545	114,3	161,7	155,7	3/4 x 2	14	192
5040	101,6	177,6	170,7	7/8 x 2 1/4	14	271
5050	127,0	177,6	170,7	7/8 x 2 1/4	14	271

# / Bore Sizes & Keyway Dimensions

Bush No.	Bore size in mm and inch	Keyway
1008	mm 10 - 22	Standard
	mm 24 - 25	Shallow
	in. 1/2 - 7/8	Standard
	in. 1 5/6 - 1	Shallow
1108	mm 10 - 25	Standard
	mm 28	Shallow
	in. 1/2 - 1	Standard
1210	mm 10 - 32	Standard
	in. 1/2 - 1 1/4	Standard
1215	mm 11 - 32	Standard
	in. 1/2 - 1 1/4	Standard
1310	mm 14 - 35	Standard
	in. 1/2 - 1 3/8	Standard
1610	mm 10 - 42	Standard
	in. 1/2 - 1 1/2	Standard
	in. 1 9/16 - 1 5/8	Shallow
1615	mm 14 - 40	Standard
	mm 42	Shallow
	in. 1/2 - 1 1/2	Standard
2012	mm 10 - 50	Standard
	in. 1/2 - 2	Standard
2517	mm 16 - 65	Standard
	in. 1/2 - 2 1/2	Standard
3020	mm 24 - 75	Standard
	in. 1 3/16 - 3	Standard

Bush No.	Bore size in mm and inch	Keyway
3030	mm 24 - 75	Standard
	in. 1 3/16 - 3	Standard
3525	mm 30 - 95	Standard
	mm 100	Shallow
	in. 1 3/16 - 3 1/4	Standard
3535	mm 30 - 90	Standard
	in. 1 3/16 - 3 1/4	Standard
	in. 3 5/16 - 3 1/2	Shallow
4030	mm 40 - 110	Standard
	mm 115	Shallow
	in. 1 7/16 - 3 3/4	Standard
	in. 3 7/8 - 4	Shallow
4040	mm 40 - 110	Standard
	in. 1 7/16 - 3 3/4	Standard
	in. 3 7/8 - 4	Shallow
4535	mm 42 - 125	Standard
	in. 1 15/16 - 4 1/4	Standard
4545	mm 42 - 115	Standard
	in. 1 15/16 - 4 1/4	Standard
5040	mm 48 - 125	Standard
	in. 2 7/16 - 5	Standard
5050	mm 48 - 125	Standard
	in. 2 7/16 - 5	Standard

## Bore in mm:

Standard keyway, the keyway follows standard DIN 6885 part 1.  
Shallow keyway, the keyway follows standard DIN 6885 part 3.

## Bore in inch:

Keyway according to BS46: Part 1  
See page 5

# / Bore Sizes & Keyway Dimensions

Keyway according to BS46: Part 1

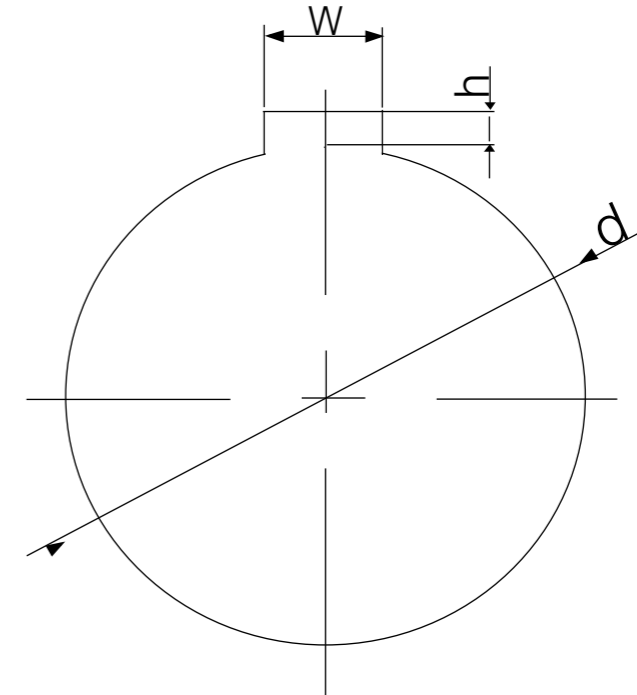

Bore Size d	Standard Keyway Dimension			
	Width w	Tolerance	Depth h	Tolerance
1/4 < d ≤ 1/2	0.125	+ 0.002 0	0.06	+ 0.01 0
1/2 < d ≤ 3/4	0.1875		0.088	
3/4 < d ≤ 1	0.25		0.115	
1 < d ≤ 1 1/4	0.3126		0.112	
1 1/4 < d ≤ 1 1/2	0.375		0.108	
1 1/2 < d ≤ 1 3/4	0.4375		0.135	
1 3/4 < d ≤ 2	0.5	0.131		
2 < d ≤ 2 1/2	0.625	+ 0.003 0	0.185	
2 1/2 < d ≤ 3	0.75		0.209	
3 < d ≤ 3 1/2	0.875		0.264	
3 1/2 < d ≤ 4	1.0		0.318	
4 < d ≤ 5	1.25		0.366	

Bush no.	Bore Size	Shallow Keyway Dimension			
		Width w	Tolerance	Depth h	Tolerance
1008	15/16, 1	0.25	+ 0.002 0	0.05	+ 0.01 0
1108	1 1/16, 1 1/8	0.3126		0.05	
1610 1615	1 9/16, 1 5/8	0.4375		0.103	
3525 3535	3 5/16, 3 3/8 3 7/16, 3 1/2	0.875	+ 0.003 0	0.20	
4030 4040	3 7/8, 3 15/16, 4	1.0		0.192	
4535 4545	4 3/8, 4 7/16, 4 1/2	1.25		0.18	

# / Torque Values

Bush size	Bore Diameter [mm]	Values for transmittable torque without key [Nm ]	Values for tightening [Nm]
1008	12	29	5,6
	19	51	
	24	66	
1108	12	28	5,6
	19	49	
	24	64	
1210/15	16	82	20
	19	105	
	24	142	
	32	210	
1610/15	19	98	20
	24	135	
	38	240	
	42	265	
2012	24	165	31
	38	310	
	42	340	
	48	400	
	50	420	
2517/25	24	220	48
	38	320	
	42	430	
	48	510	
	55	600	
	60	670	

Bush size	Bore Diameter [mm]	Values for transmittable torque without key [Nm ]	Values for tightening [Nm]
3020/30	38	520	90
	48	730	
	55	890	
	60	970	
3525/35	75	1300	112
	42	1000	
	60	1580	
	75	2150	
4030/40	90	2600	170
	100*	3075	
	48	1700	
	60	2300	
	75	3900	
4535/45	100	4400	192
	115*	5150	
	55	2500	
	75	3900	
	100	5500	
5040/50	110	6300	271
	125*	6625	
	75	3950	
	100	5650	
	125	7370	
	130*	7725	

\* Bore diameter is only available in short bush type



## Installation instruction for pulleys

### To Assemble

1. Clean and degrease the bore and taper surfaces of the bush and the tapered bore of the pulley. Insert the bush into the pulley hub and line up holes (half thread holes must line up with half straight holes).
2. Lightly oil the grub (bush size 1008 to 3030) or the cap screws (bush size 3535 to 5050) and screw them in, do not tighten yet.
3. Clean and degrease the shaft. Fit pulley with taper bush on shaft and locate in desired position.
4. When using a key it should first be fitted in the shaft keyway. There should be a top clearance between the keyway in the bore.
5. Using a hexagon socket wrench (DIN911) gradually and tighten the grub cap screws in accordance with the torques as listed in the schedule of screw tightening torques above.
6. When the drive has been operating under load for a period (half to one hour) check and ensure that the screws remain at the appropriate tightening torque.
7. In order to eliminate the ingress of dirt fill all empty holes with grease.

### Removal

1. Loosen and remove all the screws and place them in the empty holes in the bushing.
2. Tighten the screws alternately till the hub's grip on the bushing is loosened. The inner bore of the bushing can be slid on the shaft.
3. Remove the bushing from the shaft.

# / AUTHORISED DISTRIBUTORS

## ➤ Acorn Industrial Services Ltd

Unit A, Denby Way,  
Hellaby Industrial Estate,  
Rotherham, S66 8HR

T: +441709 789 999

E: enquiries@acorn-ind.co.uk

W: www.acorn-ind.co.uk

## ➤ Arkov, SPOL. S R.O.

Secska 861, 538 21  
Slatinany, Czechia.

T: +420 469 364 111

E: arkov@arkov.cz

W: www.arkov.cz

## ➤ Bell

Ptujska cesta 13, Miklavž na  
Dravskem polje, Slovenia.

T: +386 26296920

E: info@bell.si

W: www.bell.si

## ➤ Industrial CZ, SPOL. S R.O.

K Hutím 1040/4, 198  
00 Praha 9.

T: +420 283 891 466

E: industrial@industrial.cz

W: www.industrial.cz

## ➤ Jens S. Tranmissioner A/S

Hørskættten 7, DK-2630  
Taastrup, Denmark.

T: +45 70 13 83 33

E: info@jens-s.dk

W: www.jens-s.dk

## ➤ OY Jens S. AB

Martinkyläntie 52  
01720 Vantaa, Finland.

T: +3589 8676 7320

E: myynti@jens-s.fi

W: www.jens-s.fi

## ➤ Jens S. Transmisjoner AS

Enebakkveien 117  
0680 Oslo, Norway

T: +47 23 06 04 00

E: post@jens-s.no

W: www.jens-s.no

## ➤ Jens S. Transmisjoner AB

Säterivägen 27,  
605 97 Norrköping, Sweden

T: +46 11 19 80 00

E: forfragan@jens-s.se

W: www.jens-s.se

## ➤ Spruit Transmissies BV

Ivoorstraat 4, 1812 RE  
Alkmaar, PO Box 85, 1800  
AB Alkmaar

T: +31 072 5412000

E: sales@spruit.nl

W: www.spruit.nl

## ➤ Town & County Engineering Services

Wardentree Lane,  
Pinchbeck, Spalding, PE11  
3UG

T: +441775 725 678

E: sales@tces.co.uk

W: www.tces.co.uk

## ➤ Protorque

Registered address:  
Unit A, Denby Way,  
Hellaby Industrial Estate,  
Rotherham, S66 8HR

W: www.protorque.net

